

# Lyceum

Department/Organization --	Event Name --	Res # --	Event Date(s) --
A/V & Equipment Contact our office for more information	Setup Notes Seminar set for 150, 3 refreshment tables		
	File Saved As LYC_SS.150	Version --	Date Updated --

Standard Set  
Open Space, Stacks of Chairs

Max Capacities  
Lecture - 396  
Banquet - 224  
Exhibit - 41 Tables  
Classroom - 144  
Seminar - 150

Scale  
1 inch = 12 feet



Area  
Square Feet  
3,339

Built-In AV (rental fees may apply)  
House PA\* (up to 4 wired mics included), Computer Audio Cable, Data Projector w/Screen, Performance Lighting  
\*Performance Level PA available  
*All AV must be requested in advance.*

Contact  
HUB Event & Information Services  
Box 352230  
(206)543.8191  
hubres@uw.edu  
http://depts.washington.edu/thehub/

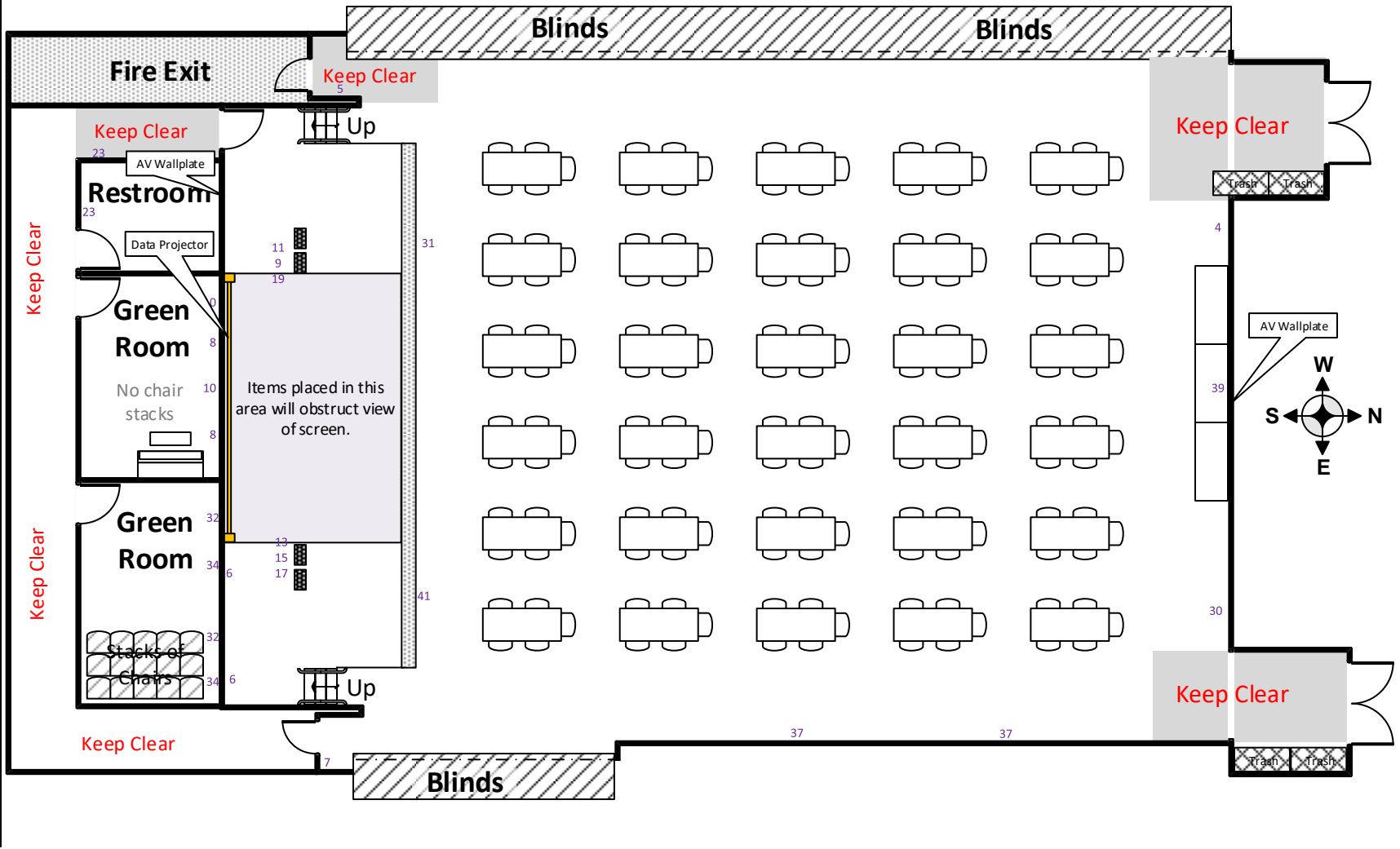

All components of the diagrams are subject to change. Illustrated diagrams and their components are estimations only. Additional furnishings (stacks of chairs/tables) not indicated on the diagram may be present in the room at the time of your reservation. Please contact our office with any additional questions.

Please sign below and return by listed due date on your confirmation. Only first contact's signature will be accepted.

Signature: \_\_\_\_\_ Date: \_\_\_\_\_

By signing this diagram, you agree to this setup. Changes on the day of event MAY not be possible. All exits and hallways must remain clear and unblocked.